

Quality and reliability is our tradition.



ISO 9001:EN 29001/BS 5750
APPROVED BY BVQI

KYORITSU

NEW

Earth Resistance Tester Series are small, lightweight and dust & drip-proof.

Earth Tester
MODEL 4102A



Digital Earth Tester
MODEL 4105A



MODEL 4102A
Soft Case Model
MODEL 4102A-H
Hard Case Model
MODEL 4105A
Soft Case Model
MODEL 4105A-H
Hard Case Model



MODEL 4102A-H
(Hard Case Model)

- Dust and drip proof. (Designed to IEC60529 IP54)
- In addition to the facility for precision measurement, test leads for simplified two wire measuring system also supplied as standard accessories. (unit can be hung from the neck for simplified measurement)
- Designed to meet IEC61010-1, IEC61557 safety standard.
- Capable of measuring earth voltage.
- Automatic warning when resistance of auxiliary earth spikes is in excess of tolerance.
- Small and lightweight. Shock resistant new case material and taut-band movement.
- 2mA measuring current permits earth resistance tests without tripping earth leakage current breakers in the circuit under test.

KEW EARTH

MODEL 4102A-4105A

INSTRUMENT LAYOUT

Earth Tester

MODEL 4102A



Digital Earth Tester

MODEL 4105A

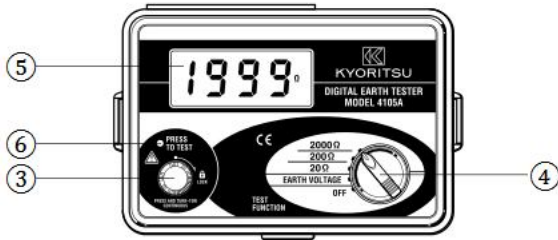

- ① Scale Board
- ② OK Lamp
- ③ Press To Test Button
- ④ Range Selector Switch
- ⑤ LCD Display
- ⑥ Indication LED With
- ⑦ Test Leads
- ⑧ Auxiliary Earth Spikes
- ⑨ Simplified Measurement Probe
- ⑩ Safety Alligator Clip
- ⑪ Test Bar

ACCESSORIES

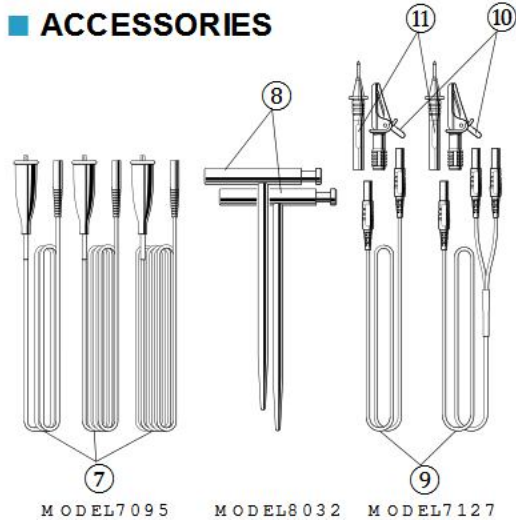

SPECIFICATIONS

	Model 4102A/4102A-H	Model 4105A/4105A-H		
Measurement Ranges	Earth Resistance: 0-12 Ω / 0-120 Ω / 0-1200 Ω Earth Voltage (50,60Hz): 0-30V AC	Earth Resistance: 0-20 Ω / 0-200 Ω / 0-2000 Ω Earth Voltage (50,60Hz): 0-200V AC		
Accuracy	Earth Resistance: ± 3% of full scale Earth Voltage: ± 3% of full scale	Earth Resistance: ± 2%rdg ± 0.1Ω (20Ω range) ± 2%rdg ± 3dgt (200Ω / 2000Ω range) Earth Voltage: ± 1%rdg ± 4dgt		
Overload Protection	Earth Resistance: 276V AC for 10 seconds across 2 of the 3 terminals Earth Voltage: 276V AC for 1 minute	Earth Resistance: 280V AC for 10 seconds across 2 of the 3 terminals Earth Voltage: 300V AC for 1 minute		
Safety Standard	IEC61010-1 CAT. III 300V Pollution Degree 2, IEC61557			
Applicable Standards	IEC60529 IP54			
Withstand Voltage	3700V AC for 1 minute			
Power Source	R6R AA (1.5V) × 6			
Dimensions	105(L) × 158(W) × 70(D) mm			
Weight	600g approx.	550g approx.		
Accessories	7095 Test Leads) × 1set (red-20m, yellow-10m, green-5m) 8032 Auxiliary earth spikes) × 1set 7127 Simplified measurement probe) × 1set R6R AA) × 6, Neck strap, Instruction Manual	<table border="1" style="width: 100%;"> <tr> <td style="text-align: center;">Carrying Case</td> </tr> <tr> <td style="text-align: center;">Soft Case 4012A, 4105A Hard Case 4012A-H, 4105A-H</td> </tr> </table>	Carrying Case	Soft Case 4012A, 4105A Hard Case 4012A-H, 4105A-H
Carrying Case				
Soft Case 4012A, 4105A Hard Case 4012A-H, 4105A-H				



Safety Warnings

Please read the "Safety Warnings" in the instruction manual supplied with the instrument thoroughly and completely for correct use. Failure to follow the safety rules can cause fire, trouble, electrical shock, etc. Therefore, make sure to operate the instrument on a correct power supply and voltage rating marked on each instrument.

※The contents of this catalogue may be subject to change without notice.

DISTRIBUTOR



KIORITSU ELECTRICAL INSTRUMENTS WORKS, LTD.

No. 5-20 Nakane 2-chome, Meguro-ku, Tokyo, 152-0031 Japan

Phone: 81-3-3723-0131 Fax: 81-3-3723-0152

URL: <http://www.kew-td.co.jp>

E-mail: info@kew-td.co.jp

Factories: Uwajima & Ehime