

Table of Contents

Title	Page
Introduction	4
Unpacking the Meter	4
Safety Information	6
International Electrical Symbols	11
The Meter Structure	12
Key Functions	14
Rotary Switch	15
Measurement Operation	16
A. Measuring Voltages	16
B. Measuring Insulation Resistance	18

Maintenance	21
A. General Service	21
B. Replacing the Battery	23
Specifications	25
Safety and Compliances	25
Physical Specifications	26
General Specifications	27
Feature Summary	27
Detailed Accuracy Specifications	28
A. Voltage Measurement	28
B. UT501: Insulation Resistance Measurement	29
UT502: Insulation Resistance Measurement	30

List of Tables

Table	Title	Page
1.	Unpacking Inspection	5
2.	International Electrical Symbols	11
3.	Meter Front Description	13
4.	Key Description	14
5.	Rotary Switch Description	15

List of Figures

Figure	Title	Page
1.	The Meter Front Structure	12
2.	Voltages Measurement	16
3.	Insulation Resistance Measurement	18
4.	Battery Replacement	23

Introduction

Uni-Trend Model UT501 and UT502 insulation resistance tester (hereafter, "the Meter") is a handheld instrument designed primarily to make resistance/ insulation resistance, DC/AC Voltage measurement.

Unpacking the Meter

The Meter includes the following items:

Table 1. Unpacking Inspection

Item	Description	Qty
1	English Operating Manual	1 piece
2	Test Lead	1 set
3	Test probe	1 set
4	Alligator clip	1 set
5	Carry bag	1 piece
6	Strap	1 piece
5	1.5V Battery (LR14)	6 pieces

In the event you find any missing or damage, please contact your dealer immediately.

Safety Information

This Meter complies with the standards IEC61010 -1 safety measurement requirement: in pollution degree 2, overvoltage category (CAT. III 600V, CAT.II 1000V) and double insulation.

CAT II: Local level, appliance, portable equipment etc., with smaller transient voltage overvoltages than CAT. III

CAT III: Distribution level, fixed installation, with smaller transient over voltages than CAT. IV

Use the Meter only as specified in this operating manual, otherwise the protection provided by the Meter may be impaired.

- ⚠ **Danger** identifies conditions and actions that pose hazard(s) to the user.
- ⚠ **Warning** identifies avoiding electric shock.
- ⚠ **Caution** identifies conditions and actions that may damage the Meter and carrying out accurate measurement.

International electrical symbols used on the Meter and in this Operating Manual are explained on page 11.

 **Danger**

Use of instrument in a manual not specified by the manufacturer may impair safety features/protection provided by the equipment. Read the following safety information carefully before using or servicing the instrument.

- **Do not apply more than 1000V DC or 750V AC.**
- **Do not use the Meter around explosive gas, vapor or dust.**
- **Do not use the Meter in a wet environment.**
- **When using the test leads, keep your fingers away from the lead contacts.**
- **Keep your fingers behind the finger guards on the leads.**
- **Do not use the Meter with any parts or cover removed.**
- **When carrying out insulation measurement, do not contact the circuit under test.**

⚠ Warning

- **Do not use the Meter if it is damaged or metal part is exposed. Look for cracks or missing plastic.**
- **Be careful when working above 30V rms, 46.7V ac rms and 70V DC. Such voltages pose a shock hazard.**
- **Do not change battery when the Meter is in wet environment.**
- **Place test leads in proper input terminals. Make sure all the test leads are firmly connected to the Meter's input terminals.**
- **Make sure the Meter is turned off when opening the battery compartment.**
- **Carefully read the operating manual before operating the Meter.**
- **Follow the operating manual all the time when using the Meter and keep the operating manual in a safe place.**
- **Wrong operation will cause incident and damage to the Meter.**





Caution

- **When performing resistance tests, remove all power from the circuit to be measured and discharge all the power.**
- **When servicing the Meter, use only the same model number or identical electrical specifications of test leads and power adaptor.**
- **Do not use the Meter if the battery indicator () shows a battery empty condition. Take the battery out from the Meter if it is not used for a long time.**
- **Do not use or store the Meter in an environment of high temperature, humidity, explosive, inflammable and strong magnetic field. The performance of the Meter may deteriorate after dampened.**

International Electrical Symbols

International symbols on the Meter and in this manual are explained in Table 2.

Table 2. International Electrical Symbols

	Equipment protected by double or reinforced insulation.
DCV	DC Measurement
ACV	AC Measurement
	Grounding
	See Manual
	Conforms to Standards of European Union

The Meter Structure

Below Figure 1 and Table 3 shows the Meter front structure and description.

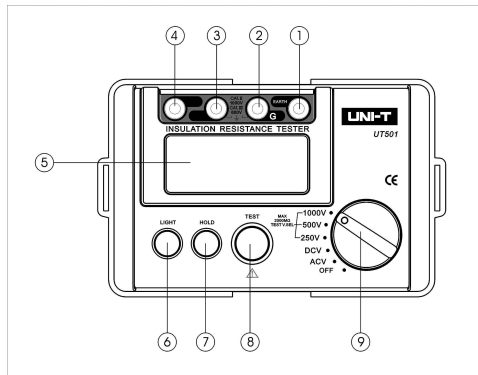

a.UT501

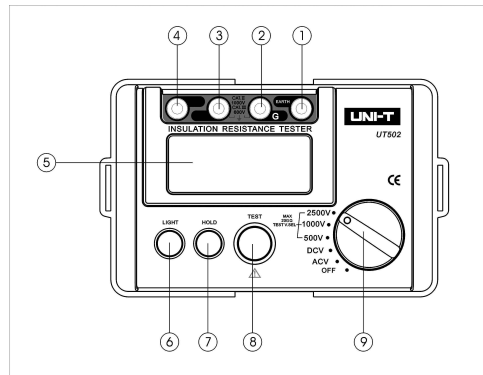

b.UT502

Figure 1. The Meter Front Structure

Table 3. Meter Front Description

1	EARTH: Resistance input terminal
2	G: Voltage Measurement input negative terminal
3	V: Voltage input terminal
4	LINE: Resistance input terminal
5	LCD
6	Display Backlight button
7	Data Hold button
8	Insulation Resistance Button
9	Rotary switch

Key Functions

Table 4. Key Description

HOLD	Press once to turn the data hold on, H is shown on the display. Press again to turn the data hold feature off. H is disappeared.
LIGHT	Press once to turn the display backlight on. Press again to turn the display backlight off.
TEST	Press to stop or start an insulation resistance test.

Rotary Switch

Table 5. Rotary Switch Description

ON/OFF	Turn on or off the Meter.
ACV	Turn the rotary switch to ACV to measure AC Voltage
DCV	Turn the rotary switch to DCV to measure DC Voltage
250V/500V/1000V (UT501)	Turn the rotary switch to 250V/500V/1000V, select the requested output voltage, to carry out insulation resistance measurement.
500V/1000V/2500V (UT502)	Turn the rotary switch to 500V/1000V/2500V, select the requested output voltage, to carry out insulation resistance measurement.

Measurement Operation

Below section explains how to make measurements.

A. Measuring Voltages

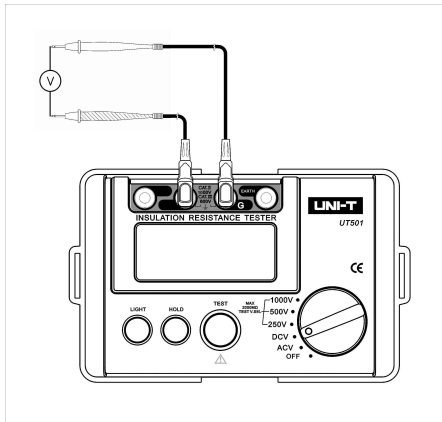

a.UT501

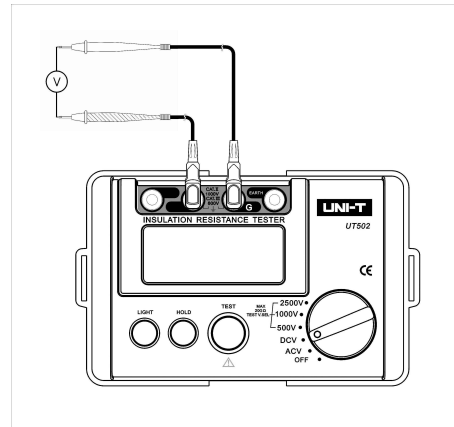

b.UT502

Figure 2. Voltages Measurement

 **Caution**

- **To avoid harm to you or damages to the Meter from electric shock, do not attempt to measure voltages higher than 1000V DC or 750V rms AC although readings may be obtained.**
- When voltage measurement has been completed, disconnect the connection between the testing leads and the circuit under test and remove testing leads away from the input terminals of the Meter.
- **Do not carry out measurement when the battery compartment is open.**

To measure voltages, set up the Meter as Figure 4 and do the following:

1. Turn the rotary switch to **DCV** or **ACV**.
2. Insert the red test lead into the **V** terminal and the black test lead into the **G** terminal.

Then carry out the measurement.

B. Measuring Insulation Resistance

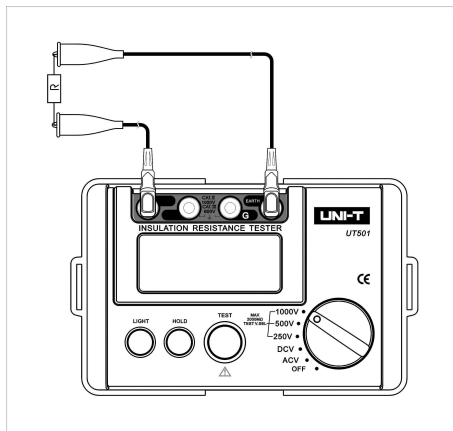

a.UT501

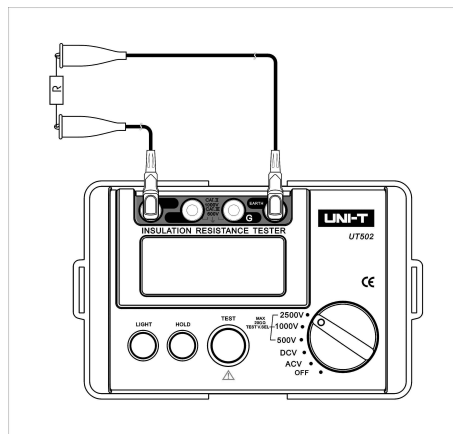

b.UT502

Figure 3. Insulation Resistance Measurement

Caution

- **When measuring insulation resistance, please must separate the two test leads.**
- **When performing insulation resistance tests, remove all power from the circuit to be measured and discharge all the power.**
- **Do not short circuit two test leads under high voltage status.**
- **Do not measure insulation resistance after high voltage output.**
- **Do not carry out measurement when the battery compartment is open.**
- **When the measurement is completed, don't touch the circuit as the circuit has already stored capacitance, which may cause electric shock.**
- **Don't touch the test leads even after it has been removed from the circuit until voltages are all released.**
- **Do not carry out measurement when the battery compartment is open.**

To measure insulation resistance, set up the Meter as Figure 3 and do the following:

- **Turn the rotary switch to one of these position 250V / 500V / 1000V / 2500V.**
 1. When performing insulation resistance tests, remove all power from the circuit to be measured and discharge all the power.
 2. Insert the red test lead into the **LINE** terminal and the black test lead into **EARTH** terminal.
 3. Connect the red and black alligator clip to the circuit to be measured, positive voltage output from **LINE** terminal.
- **Continuous Measurement**
 1. Turn the rotary switch to one of these position 250V / 500V / 1000V / 2500V
 2. Press **TEST** to button to carry out continuous measurement. Output insulation resistance testing voltage, **TEST** button light up,
 3. Press **TEST** button to close the insulation resistance measurement voltage when measurement is completed. **TEST** button lights off.

Maintenance

This section provides basic maintenance information including battery replacement instruction.

Warning

Do not attempt to repair or service your Meter unless you are qualified to do so and have the relevant calibration, performance test, and service information.

A. General Service

- Periodically wipe the case with a damp cloth and mild detergent. Do not use abrasives or solvents.
- To clean the terminals with cotton bar with detergent, as dirt or moisture in the terminals can affect readings.

- Turn the Meter to OFF when it is not in use.
- Take out the battery when it is not using for a long time.
- Do not use or store the Meter in a place of humidity, high temperature, explosive, inflammable and strong magnetic field.
- If the Meter is wet, dry it before use.

B. Replacing the Battery

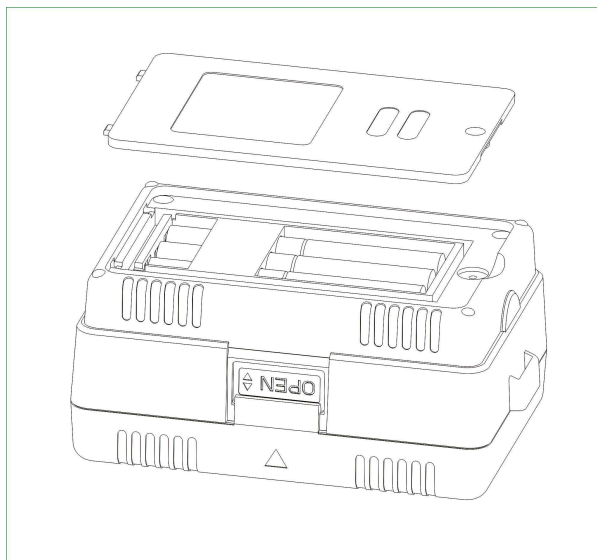

Figure 4. Battery Replacement

Caution

- **Don't mix to use old and new batteries.**
- **Be careful the polarity is correct when installing batteries.**

Danger

- **Make sure the battery compartment is closed before using the Meter**

Follow Figure 4 and proceed as follows to replace the battery:

- Turn the Meter to OFF and remove all connections from the terminals.
- Remove the screw from the battery compartment, and separate the battery compartment from the case bottom.
- Replace with 6pcs of new 1.5V (LR14) batteries.
- Rejoin the case bottom and battery compartment, and reinstall the screw.

Specifications

Safety and Compliances

Certification	CE
Compliances	IEC 61010 -1 CAT.II 1000V, CAT.III 600V overvoltage and double insulation standard

Physical Specifications

Display (LCD)	Digital: 1999 counts
Operating Temperature	0°C ~35°C (32 °F ~95 °F)
Storage Temperature	-20°C ~60°C (-4 °F ~140 °F)
Relative Humidity	≤70% @ 0°C ~35°C below; ≤80% @ -20°C ~60 °C :
Battery Type	6pcs of 1.5V (LR14) batteries
Dimensions (H x W x L)	150 x 100 x 71 mm
Weight	Approx. 0.5kg (including battery)

General Specifications

Over loading	<p>UT501:</p> <p>Display 1□□□ MΩ on insulation resistance range.</p> <p>Voltage display > 1999, display 1 □□□V.</p> <p>Overload voltage testing is not allowed in this Meter.</p> <p>UT502: Display OL when overload testing on every range.</p>
Battery Indicator	Display  .

Feature Summary

Display Backlight	Bright backlight for clear readings in poorly lighted areas.
Autorange	The Meter automatically selects best range
Warning	Red light will on when exporting high voltage.
Voltage	Auto release voltage

Detailed Accuracy Specifications

Accuracy: \pm ([a% of reading] + [number of least significant digits]), guarantee for 1 year.

Operating temperature: 18 °C ~28 °C

Relative humidity: 45~75%RH

A. Voltage Measurement

	DC Voltage	AC Voltage
Measurement Range	$\pm 30 \sim \pm 1000V$	30V~750V (50/60Hz)
Resolution	1V	
Accuracy	$\pm (2\%+3)$	

B. UT501: Insulation Resistance Measurement

Output Voltage	250V	500V	1000V
Display Range	$3\text{M}\Omega \sim 2000\text{M}\Omega$ (When around less than $4.3\text{M}\Omega$, test lead insulation is bad or invalid, buzzer will beeps)		
Open Circuit Voltage	DC250V $\pm 10\%$	DC500V $\pm 10\%$	DC1000V $\pm 10\%$
Test Current	0.9mA~1.1mA @250k Ω	0.9mA~1.1mA @500k Ω	0.9mA~1.1mA @1M Ω
Short Circuit	Around less than 1.8 mA		
Accuracy	$3\text{M}\Omega$ to $99\text{M}\Omega$: $\pm(3\%+5)$ $100\text{M}\Omega \sim 2000\text{M}\Omega$: $\pm(5\%+5)$		

UT502: Insulation Resistance Measurement

Output Voltage	500V	1000V	2500V
Display Range	3M Ω ~2G Ω (less than 3M, buzzer beeps and 0M Ω will be shown)	5M Ω ~4G Ω (less than 5M, buzzer beeps and 0M Ω will be shown)	25M Ω ~20G Ω (less than 25M, buzzer beeps and 0M Ω will be shown)
Open Circuit Voltage	DC500V \pm 10%	DC1000V \pm 10%	DC2500V \pm 10%
Test Current	0.9mA~1.1mA @500k Ω	0.9mA~1.1mA @1M Ω	0.9mA~1.1mA @2.5M Ω
Short Circuit	Around less than 1.8 mA		
Accuracy	3M Ω to 99.9M Ω : \pm (3%+1) 100M Ω ~ 10G Ω : \pm (5%+1) 10G Ω to 20G Ω : \pm (10%+1)		

**** END ****

This operating manual is subject to change without notice.